

Customer Service
1-800-338-9951

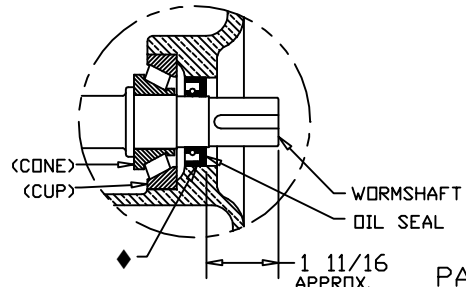
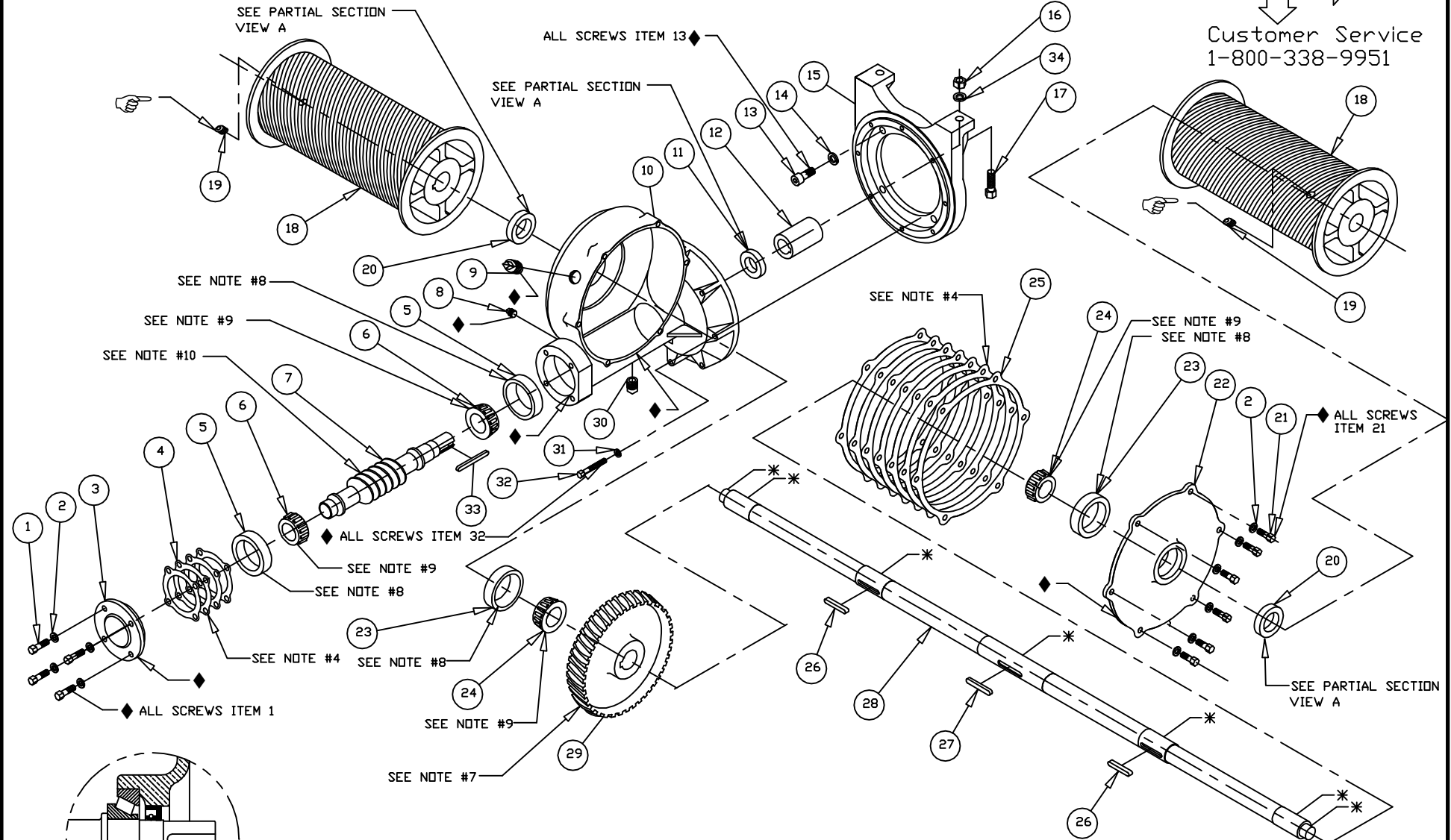

PARTIAL SECTION VIEW A

BC-Twin Hook W/ Spur Gears Monorail Gearcase Assembly Parts List Sheet 1 of 2

34	FS323	2	WASHER, L, 1/2	☒SEE NOTE A
33	K10849P3	1	KEY, 5/16x5/16, 2-15/16	
32	FS127	7	SCREW,HHCS,5/16-18x2-1/4, GR2,PLAIN	☒SEE NOTE A
31	FS312	7	WASHER,L,5/16, PLAIN	☒SEE NOTE A
30	FS333	1	PIPEPLUG,1/2 SQHD CORED,CI PLAIN	☒SEE NOTE A
29	----	1	WORM WHEEL, JOB SPECIFIC, SEE NOTE #5	
28	----	1	DRUM SHAFT, JOB SPECIFIC	
27	K10910P4	1	KEY,1/2x1/2x1-15/16,C:BC WORM WHEEL	
26	K10849P5	2	KEY, 5/16x5/16, 2, A:B DRUM SHAFT	
25	K10755	1	KIT, SHIM, B-HOIST, SIDE COVER	
24	DM7009	2	BEARING, TRB, CONE, 2.25 ID	☒SEE NOTE B
23	DM7010	2	BEARING, TRB, CUP 4.25 OD	☒SEE NOTE B
22	M1310A	1	COVER, SIDE, GEAR CASE, BC	
21	FS129	6	SCREW,HHCS,3/8-16x1, GR2,PLAIN	☒SEE NOTE A
20	DM7031	2	SEAL, SHAFT, 2.25 ID, 3.35 OD	☒SEE NOTE C
19	FS445	2	SOCKET HEAD SET SCREW, 3/8-16x1/2, KNURLED	
18	----	2	DRUM, JOB SPECIFIC	
17	FS401	2	SCREW,HHCS,1/2-13x1-3/4,GR2	☒SEE NOTE E
16	FS255	2	NUT,HEX,1/2-13, GR2,PLAIN	☒SEE NOTE E
15	M2959	1	ADAPTER, MOTOR, T477, C FACE	
14	FS320	4	WASHER,INT.TOOTH,1/2,PLATED	☒SEE NOTE A
13	FS207	4	SCREW,SHCS,1/2-13x1-1/4	☒SEE NOTE A
12	K122P2	1	SLEEVE, MOTOR SHAFT, B HOIST	
11	DM7030	1	SEAL, SHAFT, 1.18 ID, 2.06 OD	☒SEE NOTE C
10	T477A	1	GEAR CASE, BC-TH W/D SPUR GEARS	
9	FS337	1	PIPEPLUG,1/2 SQHD CORED,W/STRAIGHT VENT	☒SEE NOTE A
8	FS336	1	PIPEPLUG,1/8 SQHD,CAST IRON, SOLID	☒SEE NOTE A
7	----	1	WORM SHAFT, SEE NOTE #5	
6	DM7006	2	BEARING, TRB, CUP, 3.125 OD	☒SEE NOTE B
5	DM7005	2	BEARING, TRB, CONE, 1.25 ID	☒SEE NOTE B
4	K10756	1	KIT, SHIM, B-HOIST, END COVER	
3	K123	1	COVER, END, GEAR CASE, B	
2	FS315	10	WASHER,L,3/8, PLAIN	☒SEE NOTE A
1	FS130	4	SCREW,HHCS,3/8-16x1-1/4, GR2,PLAIN	☒SEE NOTE A
ITEM #	PART #	QTY	DESCRIPTION	

BILL OF MATERIALS

NOTES:

- 1) * - APPLY ANTISEIZE COMPOUND
- 2) ♦ - APPLY PERMATEX ULTRACOPPER SEALANT ELECTROLIFT P/N DM7394
- 3) ☞ - APPLY BLUE TYPE THREADLOCK COMPOUND, TORQUE TO 24 FT-LBS
- 4) USE THE SAME AMOUNT AND COLOR OF SHIMS AS ORIGINAL SET.
- 5) IDENTIFICATION CHART

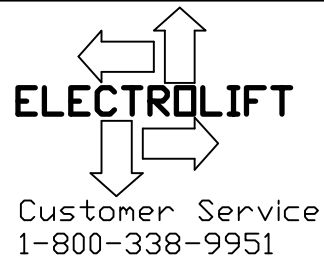

NO OF TEETH	WORM WHEEL P/N	WORM SHAFT P/N
36	M336A	M320
41	M12207A	M2851
67	M2864A	M2853

- 6) OIL CAPACITY 18 OZ.
EXXON CYLESSTIC TK680 OR EQUIV. E/L P/N DM7146
OR MOBIL SHC 634 OR EQUIV. (SYNTHETIC) E/L P/N DM7381
- 7) PRESS ITEM 25 ONTO ITEM 28 CENTRALLY LOCATED ON ITEM 26
- 8) PRESS ITEM INTO MATING HOUSING OR COVER
- 9) TO BE PRESSED ON MATING SHAFT
- 10) TAP WITH MALLET AFTER PRESSING ITEM 5

☒ KIT NOTES:

A) THIS PART CAN ONLY BE ORDERED AS PART OF GEARCASE HARDWARE KIT #K11236.

B) THIS PART CAN ONLY BE ORDERED AS PART OF GEARCASE BEARING KIT #K11318.

C) THIS PART CAN ONLY BE ORDERED AS PART OF SEAL KIT #K11319.

D) FOR BOTH SEALS & SHIMS, ORDER SEAL & SHIM KIT #K11320.

E) THIS PART CAN ONLY BE ORDERED AS PART OF HOIST HARDWARE KIT K11251.

BC-Twin Hook W/O
Spur Gears Monorail
Gearcase Assembly
Parts List
Sheet 2 of 2