

PARTIAL SECTION VIEW A

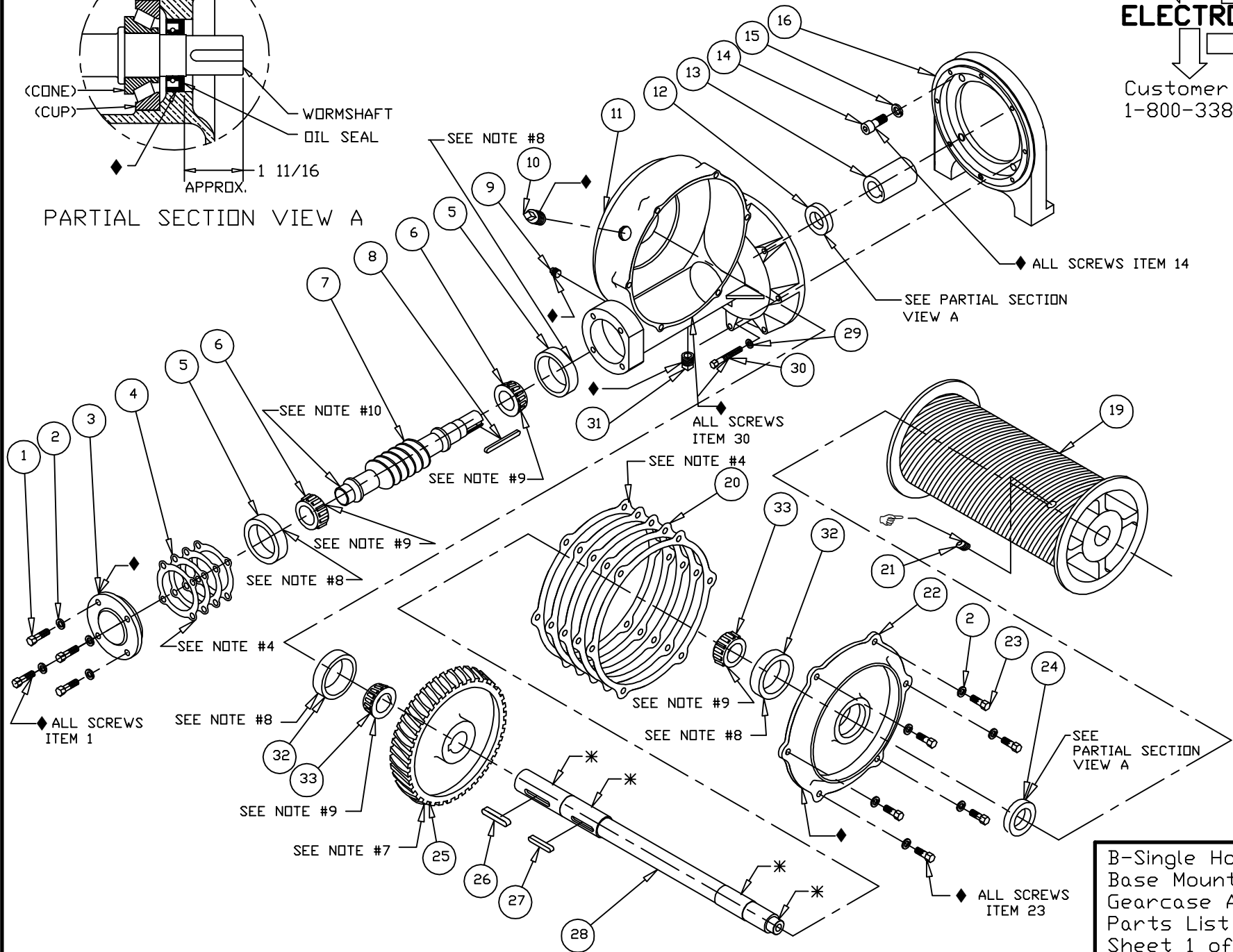

B-Single Hook
Base Mounted
Gearcase Assembly
Parts List
Sheet 1 of 2

33	DM7003	2	BEARING, TRB, CONE, 1.50 ID	☒SEE NOTE B
32	DM7004	2	BEARING, TRB, CUP, 3.00 OD	☒SEE NOTE B
31	FS333	1	PIPEPLUG,1/2 SQHD CORED,CI PLAIN	☒SEE NOTE A
30	FS127	7	SCREW,HHCS,5/16-18x2-1/4, GR2,PLAIN	☒SEE NOTE A
29	FS312	7	WASHER,L,5/16, PLAIN	☒SEE NOTE A
28	----	1	DRUM SHAFT, JOB SPECIFIC	
27	K10849P5	1	KEY, 5/16x5/16, 2, A:B DRUM SHAFT	
26	K10924P1	1	KEY, 3/8x3/8, 1-7/8, B, WORM WHEEL	
25	----	1	WORM WHEEL, SEE NOTE #5	
24	DM7028	1	SEAL,SHAFT,1.5 ID, 2.37 OD	☒SEE NOTE C
23	FS129	6	SCREW,HHCS,3/8-16x1,GR2,PLAIN	☒SEE NOTE A
22	M323	1	COVER, SIDE, GEAR CASE,B	
21	FS445	1	SOCKET HEAD SET SCREW 3/8-16x1/2, KNURLED	
20	K10755	1	KIT, SHIM, B-HOIST, SIDE COVER	
19	----	1	DRUM, JOB SPECIFIC	
18	N/A	-	-	
17	N/A	-	-	
16	M2959E	1	ADAPTER, MOTOR, T477, C FACE, FLR * BASE MTD	
15	FS320	4	WASHER,INT.TOOTH,1/2,PLATED	☒SEE NOTE A
14	FS207	4	SCREW, SHCS, 1/2-13x1-1/4	☒SEE NOTE A
13	K122P2	1	SLEEVE, MOTOR SHAFT, B HOIST	
12	DM7030	1	SEAL, SHAFT, 1.18 ID, 2.06 OD	☒SEE NOTE C
11	T477	1	GEAR CASE, B HOIST	
10	FS337	1	PIPEPLUG,1/2 SQHD CORED, W/STRAIGHT VENT	☒SEE NOTE A
9	FS336	1	PIPEPLUG,1/8 SQHD,CAST IRON, SOLID	☒SEE NOTE A
8	K10849P3	1	KEY, 5/16x5/16, 2-15/16	
7	----	1	WORM SHAFT, SEE NOTE #5	
6	DM7005	2	BEARING, TRB, CONE, 1.25 OD	☒SEE NOTE B
5	DM7006	2	BEARING, TRB, CUP, 3.125 OD	☒SEE NOTE B
4	K10756	1	KIT, SHIM, B-HOIST, END COVER	
3	K123	1	COVER, END, GEAR CASE, B	
2	FS315	10	WASHER,L,3/8, PLAIN	☒SEE NOTE A
1	FS130	4	SCREW,HHCS,3/8-16x1-1/4,GR2,PLAIN	☒SEE NOTE A
ITEM #	PART #	QTY	DESCRIPTION	

BILL OF MATERIALS

NOTES:

- 1) * - APPLY ANTISEIZE COMPOUND
- 2) ♦ - APPLY PERMATEX ULTRACOPPER SEALANT ELECTROLIFT P/N DM7394
- 3) ☞ - APPLY BLUE TYPE THREADLOCK COMPOUND, TORQUE TO 24 FT-LBS
- 4) USE THE SAME AMOUNT AND COLOR OF SHIMS AS ORIGINAL SET.
- 5) IDENTIFICATION CHART

NO OF TEETH	WORM WHEEL P/N	WORM SHAFT P/N
36	M321A	M320
41	M2852A	M2851
67	M2854A	M2853
- 6) OIL CAPACITY 18 OZ. EXXON CYLESSTIC TK680 OR EQUIV. E/L P/N DM7146 OR MOBIL SHC 634 OR EQUIV. (SYNTHETIC) E/L P/N DM7381
- 7) PRESS ITEM 25 ONTO ITEM 28 CENTRALLY LOCATED ON ITEM 26
- 8) PRESS ITEM INTO MATING HOUSING OR COVER
- 9) TO BE PRESSED ON MATING SHAFT
- 10) TAP WITH MALLET AFTER PRESSING ITEM 5

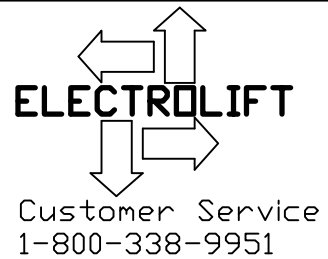

☒ KIT NOTES:

- A) THIS PART CAN ONLY BE ORDERED AS PART OF GEARCASE HARDWARE KIT #K11236.
- B) THIS PART CAN ONLY BE ORDERED AS PART OF GEARCASE BEARING KIT #K11155.
- C) THIS PART CAN ONLY BE ORDERED AS PART OF SEAL KIT #K11156.
- D) FOR BOTH SEALS & SHIMS, ORDER SEAL & SHIM KIT #K11280.

B-Base Mounted Gearcase Assembly Parts List Sheet 2 of 2