

ELECTROLIFT
 Customer Service
 1-800-338-9951

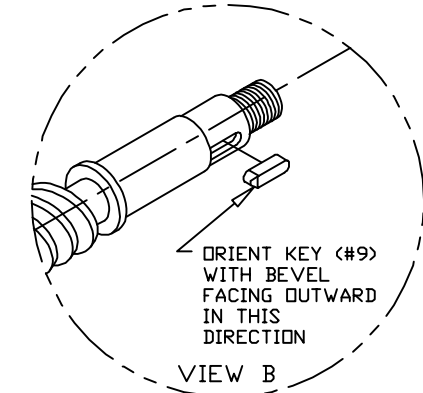
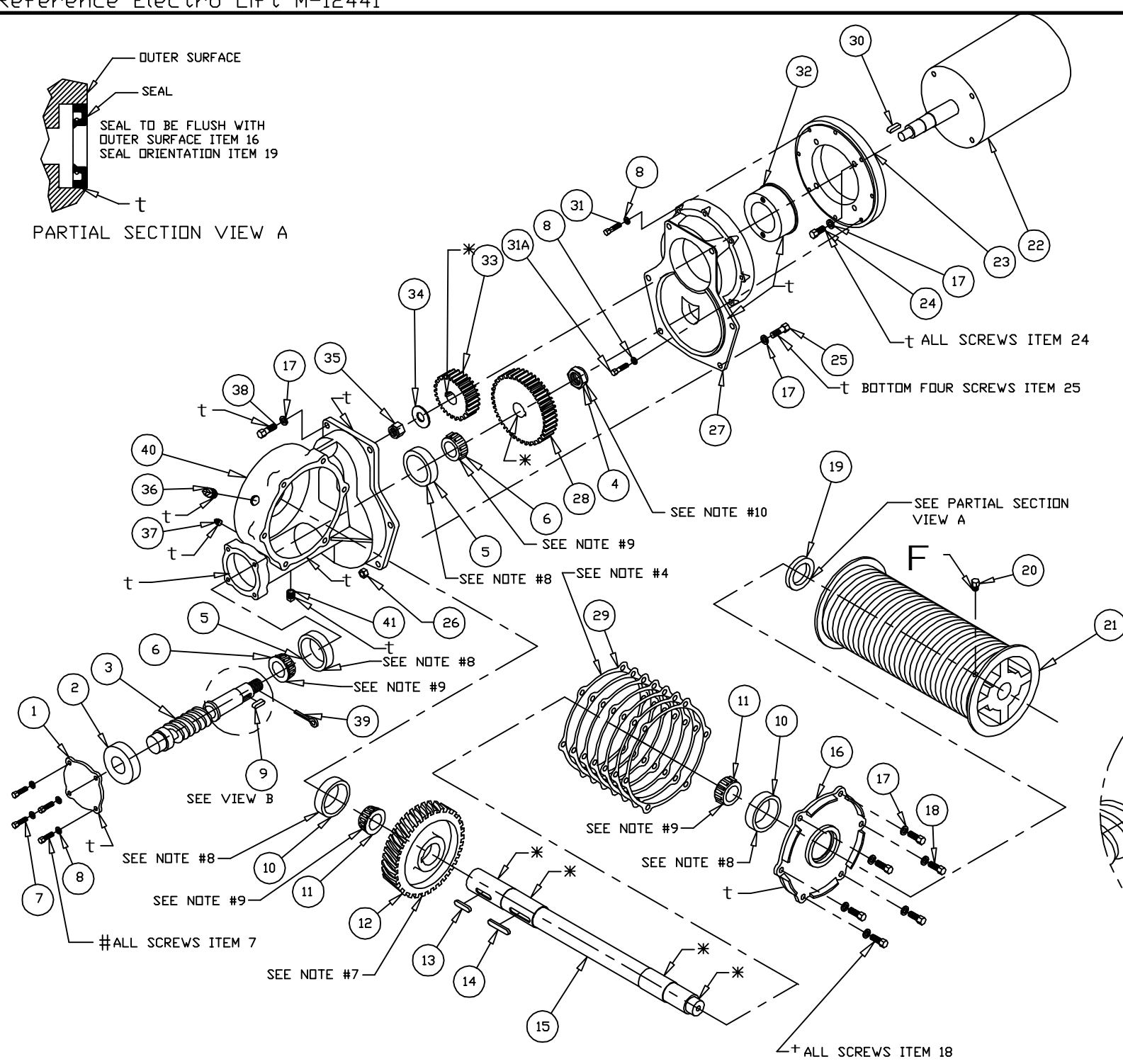

C-Single Hook
 Gearcase Assembly
 Parts List
 Sheet 1 of 2

41	FS333	1	PIPEPLUG,1/2 SQHD CORED,CI PLAIN	○SEE NOTE A
40	T479	1	GEAR CASE, C HOIST	
39	FS363	1	PIN,COTTER,5/32x1-3/4	○SEE NOTE A
38	FS391	2	SCREW,SHCS,1/2-13x2	○SEE NOTE A
37	FS336	1	PIPEPLUG,1/8 SQHD,CAST IRON, SOLID	○SEE NOTE A
36	FS337	1	PIPEPLUG,1/2 SQHD CORED,/STRAIGHT VENT	○SEE NOTE A
35	FS421	1	NUT,NYLON INSERT,7/8-14,GR2,PLAIN	○SEE NOTE A
34	FS327	1	WASHER,L,7/8, PLAIN	○SEE NOTE A
33	----	1	PINION, JOB SPECIFIC	-- SEE NOTE #11
32	K11046	1	ASSY, HOLDER, BEARING, C HOIST	
31A	FS131	2	SCREW,HHCS,3/8-16x1-1/2, GR2,PLAIN	○SEE NOTE A
31	FS132	5	SCREW,HHCS,3/8-16x1-3/4, GR2,PLAIN	○SEE NOTE A
30	K10924P2	1	KEY, 3/8x3/8, 1-7/16, GEAR, PINION,C	
29	K10755	1	KIT, SHIM, B & C HOIST, SIDE COVER	
28	----	1	GEAR, JOB SPECIFIC	-- SEE NOTE #11
27	P409	1	ADAPTOR, MOTOR, C	
26	FS255	4	NUT,HEX,1/2-13,GR2,PLAIN	○SEE NOTE A
25	FS147	4	SCREW,HHCS,1/2-13x2	○SEE NOTE A
24	FS145	4	SCREW,HHCS,1/2-13x, 1GR2,PLAIN	○SEE NOTE A
23	K3387A	1	RING, ADAPTOR, MOTOR, C HOIST	
22	----	1	MOTOR, C-HOIST, JOB SPECIFIC	
21	----	1	DRUM, JOB SPECIFIC	
20	FS216	1	SCREW,SHSS,1/2-13x1/2,KNURLED	
19	DM7031	1	SEAL, SHAFT, 2.25 ID, 3.35 OD	
18	FS146	6	SCREW,HHCS,1/2-13x1-1/4, GR2,PLAIN	○SEE NOTE A
17	FS323	16	WASHER,L,1/2, PLAIN	○SEE NOTE A
16	M335P1	1	COVER, SIDE, GEAR CASE, C	
15	----	1	DRUM SHAFT, JOB SPECIFIC	
14	K10910P3	1	KEY, 1/2x1/2, 2-5/8, DRUM, C, 3P-D	
13	K10910P4	1	KEY, 1/2x1/2, 1-15/16	
12	----	1	WORM WHEEL, JOB SPECIFIC	-- SEE NOTE #5
11	DM7009	2	BEARING, TRB, CONE, 2.25 ID	○SEE NOTE B
10	DM7010	2	BEARING, TRB, CUP, 4.25 OD	○SEE NOTE B
9	K10924P3	1	KEY, 3/8x3/8, 1-1/4, C WORM SHAFT:	SEE VIEW B
8	FS315	11	WASHER,L,3/8, PLAIN	○SEE NOTE A
7	FS130	4	SCREW,HHCS,3/8-16x1-1/4	○SEE NOTE A
6	DM7011	2	BEARING, TRB, CONE, 1.62 OD	○SEE NOTE B
5	DM7012	2	BEARING, TRB, CUP, 3.75 OD	○SEE NOTE B
4	FS437	1	NUT,NYLON INSERT,JAM,1-1/4-12	○SEE NOTE A
3	----	1	WORM SHAFT, JOB SPECIFIC	-- SEE NOTE #5
2	DM7015	1	BEARING, BALL, 6309Z, 1.77ID, 3.93 D,98W	○SEE NOTE B
1	K160	1	COVER, END, GEAR CASE, C	
ITEM #	PART #	QTY	DESCRIPTION	

BILL OF MATERIALS

○ KIT NOTES:

A) THIS PART CAN ONLY BE ORDERED AS PART OF GEARCASE HARDWARE KIT #K11263.

B) THIS PART CAN ONLY BE ORDERED AS PART OF GEARCASE BEARING KIT #K11162.

C) FOR SEAL & SHIMS, ORDER SEAL & SHIM KIT #K11287.

NOTES:

- 1) * - APPLY ANTISEIZE COMPOUND
- 2) † - APPLY PERMATX ULTRACOPPER SEALANT ELECTROLIFT P/N DM7394
- 3) F - APPLY BLUE TYPE THREADLOCK COMPOUND, TORQUE TO 52 FT-LBS
- 4) USE THE SAME AMOUNT AND COLOR OF SHIMS AS ORIGINAL SET.
- 5) IDENTIFICATION CHART

NO OF TEETH	WORM WHEEL P/N	WORM SHAFT P/N
36	M336A	M337
67	M2864A	M2988

- 6) OIL CAPACITY 100 OZ. EXXON CYLESSTIC TK680 OR EQUIV. E/L P/N DM7146 OR MOBIL SHC 634 OR EQUIV. (SYNTHETIC) E/L P/N DM7381
- 7) PRESS ITEM 12 ONTO ITEM 15 CENTRALLY LOCATED ON ITEM 13
- 8) PRESS ITEM INTO MATING HOUSING OR COVER
- 9) TO BE PRESSED ON MATING SHAFT
- 10) A. TIGHTEN NUT (ITEM #4) UNTIL THE GEAR CANNOT BE TURNED BY HAND
 B. LOOSEN NUT (ITEM #4) APROX. 45°.
 C. TAP WORM SHAFT (ITEM #3) ON NUT SIDE WITH BRASS DRIFT AND HAMMER.
 D. SPIN GEAR(ITEM 28) BY HAND. THE GEAR MUST BE ABLE TO SPIN TWO FULL REVOLUTIONS EASILY WITHOUT ANY HELP BY HAND.
 E. ADJUST NUT(ITEM #4) UNTIL THE TWO FULL REVOLUTIONS IS REACHED
 F. TAP WORM SHAFT (ITEM #3) AS PER NOTE #10, C. EVERYTIME A NUT (ITEM #4) ADJUSTMENT IS MADE.
- 11) IDENTIFICATION CHART
 PINION- THE SMALLER OF THE TWO GEARS, GEAR- THE LARGER GEAR
 PINIONS AND GEARS ARE MATCHED SETS AS KITS

KIT	# TEETH	PINION P/N	# TEETH	GEAR P/N
K11203P1	16	K3166P7	52	K3165P7
K11203P2	17	K3166P10	51	K3165P10
K11203P3	18	K3166AP19	50	K3165AP19
K11203P4	19	K3166AP21	49	K3165AP21
K11203P5	20	K3166P1	48	K3165P1
K11203P6	21	K3166AP24	47	K3165AP24
K11203P7	22	K3166P3	46	K3165P3
K11203P8	23	K3166AP16	45	K3165AP16
K11203P9	24	K3166AP20	44	K3165AP20
K11203P10	25	K3166P5	43	K3165P5
K11203P11	26	K3166P8	42	K3165P8
K11203P12	27	K3166AP23	41	K3165AP23
K11203P13	28	K3166AP14	40	K3165AP14
K11203P14	29	K3166AP22	39	K3165AP22

