

Customer Service  
1-800-338-9951

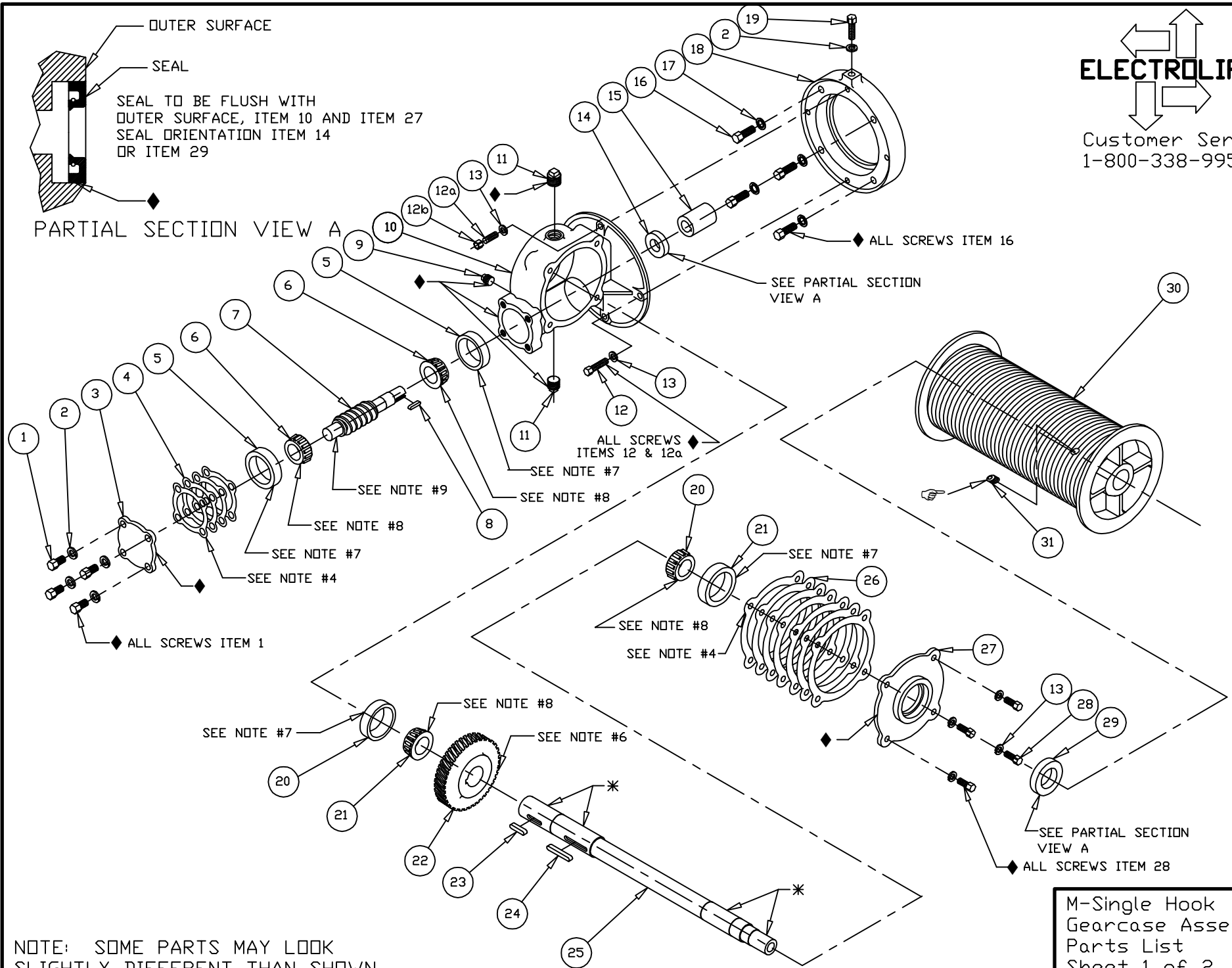

OUTER SURFACE  
SEAL  
SEAL TO BE FLUSH WITH  
OUTER SURFACE, ITEM 10 AND ITEM 27  
SEAL ORIENTATION ITEM 14  
OR ITEM 29

PARTIAL SECTION VIEW A

SEE PARTIAL SECTION  
VIEW A

ALL SCREWS  
ITEMS 12 & 12a

ALL SCREWS ITEM 1

SEE PARTIAL SECTION  
VIEW A  
ALL SCREWS ITEM 28

NOTE: SOME PARTS MAY LOOK  
SLIGHTLY DIFFERENT THAN SHOWN

M-Single Hook  
Gearcase Assembly  
Parts List  
Sheet 1 of 2

31	FS445	1	SOCKET HEAD SET SCREW 3/8-16x1/2, KNURLED
30	----	1	DRUM, JOB SPECIFIC
29	DM7035	1	SEAL, SHAFT, 1.25 ID, 2.12 OD <input checked="" type="checkbox"/> SEE NOTE C
28	FS120	4	SCREW,HHCS,5/16-18x3/4, GR2 <input checked="" type="checkbox"/> SEE NOTE A
27	M1304	1	COVER, SIDE, GEAR CASE, M, W/ GUARD
26	K10751	1	KIT, SHIM, SDT-M, SIDE COVER
25	----	1	DRUM SHAFT, JOB SPECIFIC
24	K10846P5	1	KEY, 1/4x1/4,1-3/4
23	K10846P3	1	KEY, 1/4x1/4, 1-1/8, K4005, M-2693
22	K958A	1	WORM WHEEL, M HOIST AND TROLLEY, 40T, 40:1
21	DM7213	2	BEARING, TRB, CONE, 1.25 ID <input checked="" type="checkbox"/> SEE NOTE B
20	DM7214	2	BEARING, TRB, CUP, 2.31 OD <input checked="" type="checkbox"/> SEE NOTE B
19	FS130	1	SCREW,HHCS,3/8-16x1-1/4, GR2,PLAIN <input checked="" type="checkbox"/> SEE NOTE A
18	K3314	1	ADAPTOR, MOTOR, P-419, M HOIST
17	FS317	4	WASHER,INT.TOOTH,3/8,PLATED <input checked="" type="checkbox"/> SEE NOTE A
16	FS447	4	SCREW,SHCS,3/8-16x1 <input checked="" type="checkbox"/> SEE NOTE A
15	K963	1	SLEEVE, MOTOR SHAFT, M HOIST
14	DM7034	1	SEAL, SHAFT, .75 ID, 1.50 OD <input checked="" type="checkbox"/> SEE NOTE C
13	FS312	8	WASHER,L,5/16 , PLAIN <input checked="" type="checkbox"/> SEE NOTE A
12b	FS253	1	NUT,HEX,5/16-18 <input checked="" type="checkbox"/> SEE NOTE A
12a	FS610	1	THREADEDSTUD,FULLY,5/16-18x2 <input checked="" type="checkbox"/> SEE NOTE A
12	FS126	3	SCREW,HHCS,5/16-18x1-1/2, GR2,PLAIN <input checked="" type="checkbox"/> SEE NOTE A
11	FS334	2	PIPEPLUG,1/4,SQHD,STEEL <input checked="" type="checkbox"/> SEE NOTE A
10	P419	1	GEAR CASE, M HOIST
9	FS336	1	PIPEPLUG,1/8 SQHD,CAST IRON, SOLID <input checked="" type="checkbox"/> SEE NOTE A
8	K10845P3	1	KEY, 3/16x3/16x1-11/16
7	K957	1	WORM SHAFT, M HOIST AND TROLLEY, FOR 40T, 40:1
6	DM7211	2	BEARING, TRB, CONE, .75 ID <input checked="" type="checkbox"/> SEE NOTE B
5	DM7212	2	BEARING, TRB, CUP, 2.12 OD <input checked="" type="checkbox"/> SEE NOTE B
4	K10752	1	KIT, SHIM, SDT-M, END COVER
3	K960	1	COVER, END, GEAR CASE, M
2	FS315	5	WASHER,L,3/8, PLAIN <input checked="" type="checkbox"/> SEE NOTE A
1	FS466	4	SCREW,HHCS,3/8-16x7/8, GR2,PLAIN <input checked="" type="checkbox"/> SEE NOTE A
ITEM #	PART #	QTY	BILL OF MATERIALS/DESCRIPTION

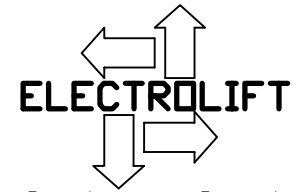

Customer Service  
1-800-338-9951

NOTES:

- 1) \* - APPLY ANTISEIZE COMPOUND
- 2) ♦ - APPLY PERMATEX ULTRACOPPER SEALANT
- 3) ☞ - APPLY BLUE TYPE THREADLOCK COMPOUND,
- 4) USE THE SAME AMOUNT AND COLOR OF SHIMS AS ORIGINAL SET.
- 5) OIL CAPACITY 8 OZ. EXXON CYLESSTIC TK680 OR EQUIV. E/L P/N DM7146 MOBIL SHC 634 OR EQUIV. (SYNTHETIC) E/L P/N DM7381
- 6) PRESS ITEM 22 ONTO ITEM 25 CENTRALLY LOCATED ON ITEM 23
- 7) PRESS ITEM INTO MATING HOUSING OR COVER
- 8) TO BE PRESSED ON MATING SHAFT
- 9) TAP WITH MALLET AFTER PRESSING ITEM 6

KIT NOTES:

A) THIS PART CAN ONLY BE ORDERED AS PART OF GEARCASE HARDWARE KIT #K11270.

B) THIS PART CAN ONLY BE ORDERED AS PART OF GEARCASE BEARING KIT #K11164.

C) THIS PART CAN ONLY BE ORDERED AS PART OF GEARCASE SEAL KIT #K11165.

D) FOR BOTH SEALS & SHIMS, ORDER SEAL & SHIM KIT #K11283.

M-Single Hook  
Gearcase Assembly  
Parts List  
Sheet 2 of 2